



## Floor Drains and Collecting Tanks Floor Drain with Stainless Steel Grate - Horizontal outlet 300x300 mm

ITEM # \_\_\_\_\_

MODEL # \_\_\_\_\_

NAME # \_\_\_\_\_

SIS # \_\_\_\_\_

AIA # \_\_\_\_\_

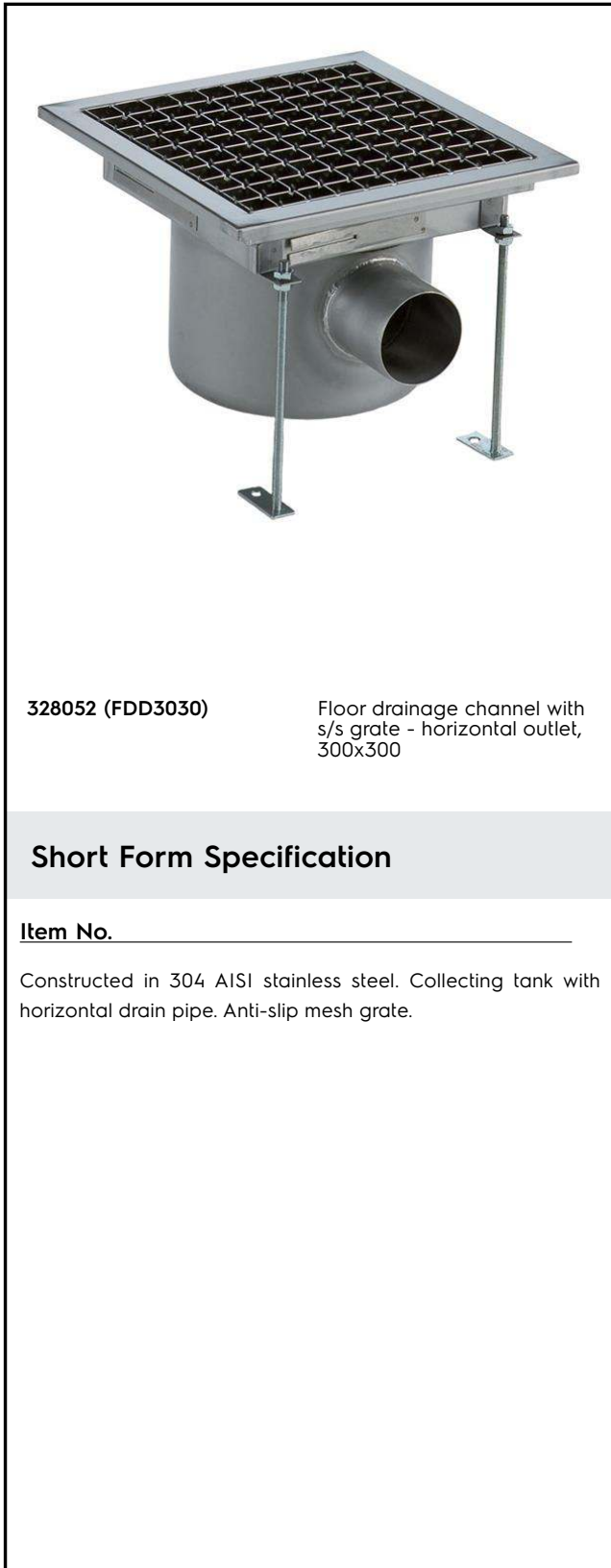

328052 (FDD3030)

Floor drainage channel with  
s/s grate - horizontal outlet,  
300x300

### Short Form Specification

Item No. \_\_\_\_\_

Constructed in 304 AISI stainless steel. Collecting tank with horizontal drain pipe. Anti-slip mesh grate.

### Main Features

- Easy to install.
- Anti-odour syphon.
- Removable waste blocking filter.
- Rag bolt for floor fixing.
- Easy to inspect for any possible waste removal action.
- Electrochemical finishing gives grids a bright appearance.
- Ideal for any drain solution, particularly suggested for great amounts of water drained during cleaning operations.

### Construction

- Adjustable leveling feet.
- Anti-slip mesh 25x25 mm grating, h=25 mm, 1.5 mm in thickness.
- Top cover available with perforated surface or with stainless steel grid.
- Constructed entirely in 304 AISI stainless steel.
- Collecting tanks available with horizontal drain pipe.

APPROVAL: \_\_\_\_\_



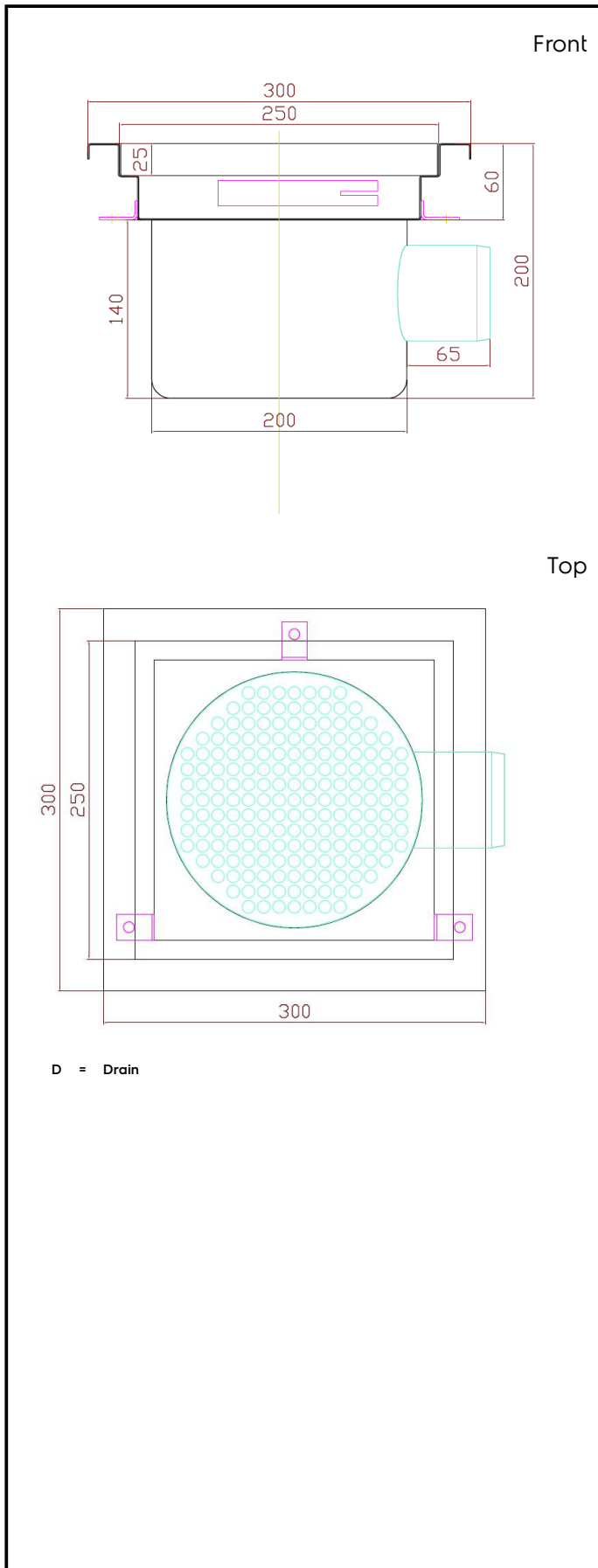

#### Key Information:

External dimensions, Width:	300 mm
328052 (FDD3030)	300 mm
External dimensions, Depth:	300 mm
External dimensions, Height:	200 mm
Net weight:	10 kg